

Smart DML

Multi-pass rotary and DTH drilling

Hole diameter: 5 7/8 to 10 5/8 inches (150 to 270 mm)



A legend, evolved for the future.

The Smart DML is built on the proven structure of the classic DML, one of the most versatile drills in the mining industry. Now enhanced with Epiroc's Rig Control System (RCS 5), the Smart DML combines trusted reliability with advanced automation features to support safer, more productive, and more connected drilling operations.

Epiroc's heavy-duty DML is one of the world's most popular drills - for good reason. It has been proven in some of the toughest mining conditions, delivering productivity, reliability, and low operating costs year after year.

The DM series is so woven into the fabric of the industry that many operators learned to drill holes with a DML. Today, you'll find these drills operating in over 50 different countries around the world.

+ Key benefits

Built for the job

The Smart DML is a crawler-mounted, hydraulic tophead-drive rig that's suitable for a variety of multi-pass rotary and DTH drilling applications. It's designed specifically for production blasthole drilling to depths of 175 ft (53.3 m) with a 30 ft (9.1 m) pipe change or 205 ft (62.5 m) with the optional 35 ft (10 m) pipe change.

Powerful performance

Feed pressure generates a pull-down of up to 60,000 lbf (267 kN), utilizing a diesel engine to drive the air compressor and hydraulic system. The powerful rotary tricone and DTH hammer drill delivers a hole diameter of 5 7/8 to 10 5/8 inches (150 mm to 270 mm) and can achieve a clean hole 32.5 ft (9.9 m) in single-pass applications or depths of up to 205 ft (62.5 m) in multi-pass applications.

Options to fit your application

Choose from a variety of compressors to create the right configuration for your drilling operation.



Discover more about the Smart DML

Robust, double-cut structural tower lacing offers strength without the added weight of less efficient designs and is designed for long life in the toughest mining conditions.

Spacious one-piece FOPS (Falling Object Protective Structure)-rated cab is designed for visibility and operator comfort.

Electronic Air Regulation System (EARS) allows you to easily adjust your compressor to save horsepower and fuel consumption for a lower total cost of ownership.

Main frame features welded rectangular tubing, verified by dynamic strain gauging.



Smart DML — Designed for maximum productivity and value



Enhanced safety

The Smart DML is equipped with a number of features designed to keep operators safe on the job. Features include a FOPS cab, safety interlocks through RCS, and safety shutdowns for temperature, low level, and pressure.



Operator comfort

The Smart DML features an insulated, pressurized cab with an air-ride operator seat, providing high suspension comfort with excellent visibility. The cab is equipped with our Rig Control System (RCS), providing onboard automation capabilities as part of the standard drill package for added safety and productivity.



Ease of maintenance

The deck layout on the Smart DM series offers easy access to all major service components. Hydraulic system filters are also mounted externally for accessibility. The integrated A/C system is mounted on the side, so no roof access is required, and the central lubrication manifold streamlines maintenance. To make service even easier, optional ground-level, quick-connect fittings are available for fast fill and evacuation of fuel, hydraulic oil, engine coolant, and other fluids.

Flexibility for the future



Epiroc's Rig Control System (RCS) is based on proven CAN-bus technology, and comes standard on the Smart DML. RCS provides a number of safety and interlock features, as well as a foundation to add new functionality and options later without a major rebuild of the machine. With RCS, you can run your Smart DML with an operator on board using options such as AutoDrill 2 and AutoLevel - or you can run with the operator off the drill with the optional BenchREMOTE package, allowing one operator to run one or multiple units. You can even implement autonomous drilling with almost no human interaction with the drill.

Standard features:

AutoDrill 2

Executes fast, safe, and efficient drilling processes in a consistent way.

AutoLevel

Closes the gap between less experienced and expert operators.

Office pack

Includes:

- **Common Communications Interface (CCI)**
Allows data transfer to and from RCS.
- **Rig Remote Access (RRA)**
Wirelessly sends files to and from the drill rigs.
- **Desktop Viewer**
Allows remote access to the drill's operational screens.

Add-on features:

Wireless remote tramping

Allows the operator to tram a Smart DML from the bench within a 32.8 - 65.6 ft (10-20 m) distance.

High-precision GPS hole navigation system

Imports drill plans to RCS and ensures that each blasthole is precisely positioned with accuracies of up to ±3.9 in (±10 cm), depending on installation and the number of satellites.

Embedded cameras

Optional embedded 360° cameras that provide full situational awareness and safety.

Tower, carousel and drill rod handling

Tower		
Tower construction	Fully welded four main member with open front ASTM A500; rectangular steel tubing	
Tower raising	Two hydraulic cylinders; live tower (raise and lower with full carousel and rotary head at top of tower)	
Rod support	Hydraulic cylinder actuation to center drill rod	
Rated capacity		
Single pass depth (clean hole with drill bit above the table)	Standard 30 ft rod tower: 275 ft (8.4 m) Optional 35 ft rod tower: 325 ft (9.9 m)	
Maximum hole depth	Standard 30 ft rod tower: 175 ft (53.3 m) Optional 35 ft rod tower: 205 ft (62.5 m)	
Carousel (carousel internal to the tower with key-lock retention)		
Rod length	30 ft (9.1 m); 35 ft (10.7 m) optional	
Capacity	<ul style="list-style-type: none"> • Five pieces of 4-1/2 in, 5 in, or 5-1/2 in rods (114 mm, 127 mm, or 140 mm) • Four pieces of 5-1/2 in, 6-1/4 in, or 7 in (140 mm, 159 mm, or 178 mm) • Three pieces of 7 in or 7-5/8 in (178 mm or 194 mm) • Two pieces of 7-5/8 in (194 mm) 	
Actuation	Two hydraulic cylinders	
Safety	<ul style="list-style-type: none"> • Drill pipe is held securely in carousel by "key lock design" mechanism • No bump system to prevent damage if carousel not stowed 	
Drill rods		
Drill pipe diameter	Thread	Suggested bit diameter
4-1/2 in (114 mm)	3-1/2 in API	5-7/8 in - 6-3/4 in (150 mm - 171 mm)
5 in (127 mm)	3-1/2 in API or BECO	6-3/4 in - 7-3/8 in (171 mm - 187 mm)
5-1/2 in (140 mm)	3-1/2 in BECO	6-3/4 in - 7-7/8 in (171 mm - 200 mm)
6-1/4 in (159 mm)	4 in BECO	7-7/8 in - 9 in (200 mm - 229 mm)
7 in (178 mm)	4-1/2 in BECO	9 in - 9-7/8 in (229 mm - 251 mm)
7-5/8 in (194 mm)	5-1/4 in BECO	9-7/8 in - 10-5/8 in (251 mm - 270 mm)
Rotary head		
Speed range	Variable: 0 - 161 RPM	
Torque	Variable: 0 - 7,200 lbf-ft (0 - 9,762 Nm)	
Number of motors	Two	
Type of motor	One variable displacement axial piston and one fixed	
Reduction	15:1	
Travel length	35 ft 7 in (10.9 m); 40 ft 6 in (12.3 m) optional	
Feed system		
Pulldown capacity	Up to 60,000 lbf (267 kN)	
Pullback capacity	0 - 22,000 lbf (0 - 98 kN)	
Weight on bit	Variable: 0 - 60,000 lb (0 - 27,216 kg)	
Mechanism type	Hydraulic cylinders with cable feed and chains	
Pulldown cable diameter	1 in (25.4 mm)	
Pullback chain	160 H	
Feed speed	Standard 30 ft rod tower: 146 ft/min (44.5 m/min) Optional 35 ft rod tower: 109 ft/min (33.2 m/min)	
Retract speed	Standard 30 ft rod tower: 205 ft/min (62.5 m/min) Optional 35 ft rod tower: 181 ft/min (55.2 m/min)	

Technical specifications

Substructure

Mainframe	
<ul style="list-style-type: none"> • Rectangular tubing construction • Designed by Epiroc, and weld fabricated by certified welders • Designed with the latest FEA technology and verified by dynamic strain gauging 	
Leveling jack	
Type	Hydraulic cylinder
Quantity	Three (standard); Four (optional)
Calculated jack pad bearing pressure	Drill end: 68.9 psi (475 kPa) Non-drill end (4 jacks): 59.9 psi (413 kPa)
Position indication	"Jack up" indicator lights on console or RCS screen
Capacities	
Fuel tank	380 gal (1,438 L) standard 680 gal (2,574 L) optional
Water tank	300 gal (1,136 L), 400 gal (1,514 L), or 700 gal (2,650 L)
Hydraulic tank	150 gal (568 L)

Undercarriage and tramping system	
Make	Caterpillar 330S or Caterpillar 330L
Mounting	Oscillating walking beam: 5' each side, total 10'
Total length	Caterpillar 330S: 181 in (4.60 m); Caterpillar 330L: 198 in (5.02 m)
Ground contact	Caterpillar 330S: 142 in (3.61 m); Caterpillar 330L: 159 in (4.04 m)
Take-up adjustment	Grease slack adjustment; spring recoil
Rollers	Caterpillar 330S: 7 lower / 2 upper; Caterpillar 330L: 8 lower / 2 upper
Location	Equally spaced between idler and sprocket
Roller bearings	Sealed for life
Track pads	Type: Triple bar grouser Width: 33.5 in (851 mm) Ground pressure Caterpillar 330S: 13.7 psi (94 kPa) Ground pressure Caterpillar 330L: 13.2 psi (91 kPa)
Drive	Hydrostatic closed loop through planetary speed reducer
Propel motors	Two - Hydraulic, axial piston, fixed displacement rating (each): 151 HP (112.6 kW)
Propel speed range	Caterpillar: 0 - 1.3 mph (0 - 21 km/h)

Power package

Airend	
Diesel only	1,200 cfm / 110 psi (34 m³/min/7.6 bar) 1,900 cfm / 110 psi (53.8 m³/min/7.6 bar) 1,500 cfm / 350 psi (41.1 m³/min/24 bar)
Diesel engine	
Diesel engine - non Tier 4	CAT C15 - 540 HP (397 kW) CAT C27 - 800 HP (597 kW)
Diesel engine - Tier 4 Final	CAT C27 - 800 HP (597 kW)

Optional equipment

Following are some examples of available options. For a comprehensive list, please contact your local Epiroc Customer Center.

- Angle drill package - 0 to 30 degrees
- Cold weather options for drill operation in extremely cold ambient conditions (-45° C)
- Tow hooks on non-drill end
- Epiroc dust collector
- Hydraulic test station
- Water injection
- Automatic thread lube
- Bulk filtration
- Angle telescoping dust curtain
- Heavy duty rotary head
- Engine prelude
- Additional cab A/C kit

Cab and controls

Cab

- Quiet, single piece design with no seams or leaks (tested at less than 80 dBA)
- Insulated, pressurized with heater and under cab mounted air conditioning
- Falling object protective structure (FOPS) certified
- Ergonomically designed control system and excellent visibility (with unobstructed view to drill table)

Controls (Standard Rig Control System – RCS)

RCS	<p>Integrated control touchscreen (penetration rate, rotation torque, rotation pressure, pulldown force, pulldown pressure, hole depth indicator, etc.)</p> <p>Two joy sticks (attached to the operator's seat) and push buttons on the operator panel controls (propel and leveling jack, pulldown feed control, holdback feed control)</p> <p>Standard interlocks/features</p>
-----	---

Hydraulic system

- Hydraulic pumps mounted on a single three-hole gearbox driven off the engine through a drive shaft
- Hydraulic system main pumps work through diverter valves to control feed/rotation and propel
- Two main pumps
- One triple pump

Operating dimensions

	Description	Dimensions ft (m)
A	Height – tower up (30 ft rod tower) Height - tower up (35 ft rod tower)	44' 8.6" (13.63) 49' 8.6" (15.15)
B	Length - tower down (30 ft rod tower) Length - tower down (35 ft rod tower)	44' 4.6" (13.53) 49' 4.6" (15.05)
C	Length - jack center to jack center	20' 3.8" (6.19)
D	Length – undercarriage	330S: 14' 11.9" (4.57) 330L: 16' 5.8" (5.02)
F	Height – jack to ground (non drill end)	1' 6.8" (0.47)
H	Height – tower down (tower clearance)	15' 9.1" (4.80)
J	Width – track inside to track inside	7' 8.3" (2.04)
K	Width – jack center to jack center	9' 8.0" (2.95)
M	Width – overall	17' 7.7" (5.38)
N	Width – track	2' 9.5" (0.85)
Q	Height – ground to cab top	11' 10.9" (3.63)
S	Width - drill end (no dust collector)	16' 9.3" (5.11)
U	Width - cab	5' 4.3" (1.63)
V	Width - decking (non drill end)	12' 0.5" (3.67)
W	Length - decking	31' 4.7" (9.58)
Y	Length - non drill end to dust collector end	23' 9.3" (7.25)
AA	Width - tower (front view)	3' 1" (0.94)
BB	Height - jack to ground (drill end)	1' 6.8" (0.48)
CC	Length - cab to undercarriage edge	9' 0.2" (2.75)
DD	Length - cab to front jack center (front view)	8' 0.4" (2.45)

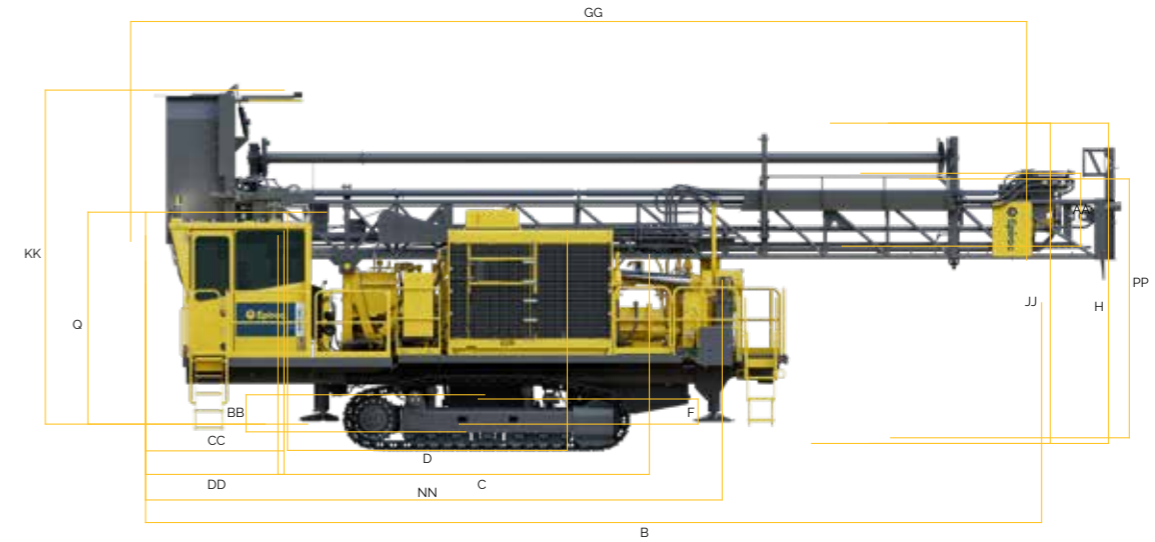

Operating dimensions (continued)

GG	Length - tower: front view (30 ft rod tower) Length - tower: front view (35 ft rod tower)	41' 11.2" (12.78) 46' 4.4" (14.26)
KK	Length - ground to dust curtain platform	18' 4.2" (5.62)
NN	Length - non drill end to cab end	32' 2.4" (9.81)
QQ	Height - ground to oscillation yoke	1' 11.8" (0.60)
RR	Length - decking edge to cab edge	2' 6.8" (0.78)
SS	Rotary head travel (30 ft rod tower) Rotary head travel (35 ft rod tower)	32' 7.6" (9.95) 37' 7.6" (11.47)
TT	Height - ground to bottom stop (30 ft rod tower) Height - ground to bottom stop (35 ft rod tower)	5' 10.2" (1.78)
WW	Width - undercarriage assembly	12' 3.7" (3.75)
XX	Width - decking (cab end to undercarriage edge)	4' 5.6" (1.36)

Shipping dimensions and weight (standard machine)

Operating weight	
Estimated weight	87,000 – 110,000 lb (39 – 50 tonnes)

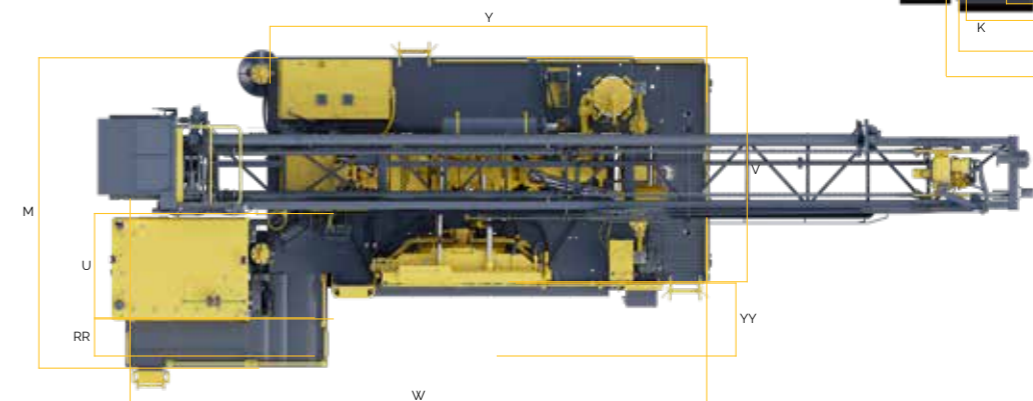

Service and support

Epiroc offers several types of service agreements to meet your operational requirements and maximize your productivity:

Variable-price repairs
Service when you need it.

Fixed-price repairs
Service with controlled costs.

Equipment audit
Scheduled equipment quality control.

Preventive maintenance programs
Peace of mind so you can focus on your core business.

