

SmartROC T25 R

Tophammer surface drill rig for quarrying and construction

Hole diameter: 38–64 mm (1.5"–2.5")



A smart rig for smarter operators.

You've never asked for much. The SmartROC T25 R gives you everything you could ever dream of.

You work alone in the background, — building the infrastructure which keeps society running smoothly. You are first on-site and the last to go home. We know how it is. Epiroc has designed the SmartROC T25 R to work as hard as you do.

It will follow you into the roughest terrain, or into tight, suburban sites. It is ready to be your new best friend and help you deliver results, shift-after-shift.



Discover more about
the SmartROC T25 R.

Your new best friend.

The SmartROC T25 R features a smart control system which presents you with all the information you need to get the job done efficiently. It features an attractive, easy-to-read 10" touchscreen so you can keep track of drilling operations and all crucial settings. The control system also automatically optimizes power output which reduces fuel consumption. This helps to keep costs low and reduce your environmental impact.

Epiroc is constantly pushing and developing updates, new features and options for SmartROC rigs. These can be installed in your SmartROC T25 R in the future thanks to the Smart control system. This helps to safeguard your investment, further boost productivity and keep your most trusted companion in top condition.

⊕ Main benefits

Impressive adaptability. Features such as a flexible boom system, compact transport position, steel or rubber tracks, three different feed lengths and air and water flushing help you get the job done.

Exceptional coverage. A 45°/45° or 90°/90° swing radius provides 26 m² or 47 m² setup coverage. Choose between two boom systems offering 6 or 5.7 meters of reach. Both booms are available with a 360° feed swing. The boom geometry means you can drill right next to the rig.

Great terrainability. A low center of gravity, wide track spacing and highly maneuverable boom enable the rig to follow you into the roughest terrain.



Compact dimensions, versatile feed with 360° swing and great lighting options means the SmartROC T25 R is just as happy underground as it is on the surface. Wherever you need to work, this rig will be right there by your side.



Powerful yet compact — the SmartROC T25 R is easy and cost effective to transport thanks to its well thought-out design. It's also simple to service thanks to large access hatches. Service points are grouped together to make life easier.



All SmartROC rigs feature an extensive options list — the SmartROC T25 R is no exception. You can select different boom and feed options, rubber or steel tracks, a powerful LED light package and a watermist system to name just a few.

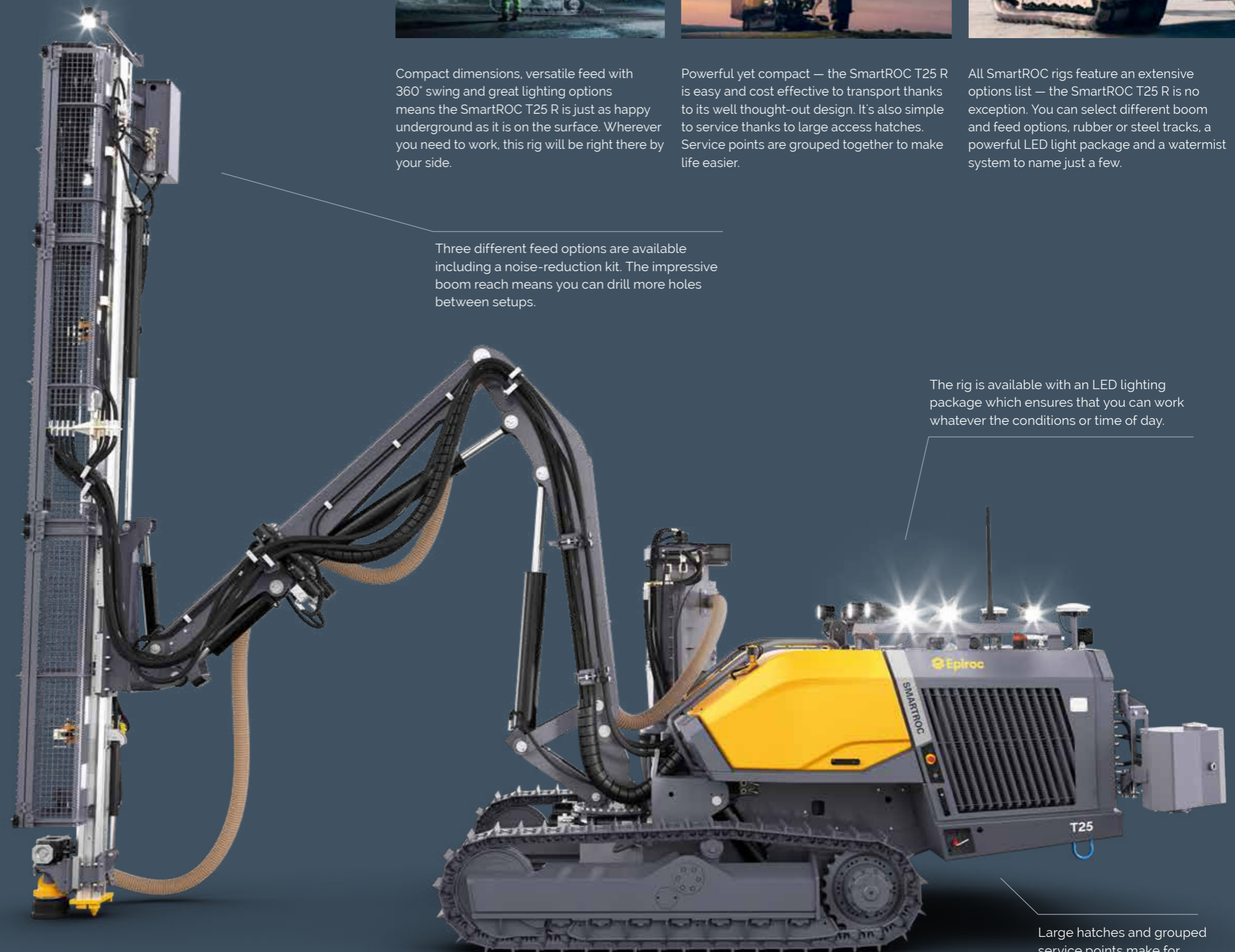

Three different feed options are available including a noise-reduction kit. The impressive boom reach means you can drill more holes between setups.

The rig is available with an LED lighting package which ensures that you can work whatever the conditions or time of day.

Large hatches and grouped service points make for quick and easy servicing.

Rubber and steel crawler track options are available. Wide track-spacing helps to increase stability.



Ready for the future.
Optimized for today.

Sometimes you have to work in the urban jungle. No problem. Wherever you need to go, the SmartROC T25 R will follow.

Not all jobs are located in the great wide open. Some sites are located in a dense, urban setting. The SmartROC T25 R is designed to be as versatile as you are. Rubber crawler tracks are available so no trace of your visit is left. The compact design and clever boom geometry ensure that you can get into just the right position for drilling.

Some locations include strict regulations regarding noise pollution. The SmartROC T25 R is available with a noise-reduction option. This allows the rig to operate problem-free in these sound-sensitive areas.

Designed for you — and all kinds of rock.

We know that your job is anything but monotonous. Each day is different, and presents you with unique problems and challenges. The SmartROC T25 R has been designed with this in mind. Impressive boom coverage, a smart control system and unrivaled adaptability all add up to make sure you get the job done safely, efficiently and on-time.



+ Smart control system

The Smart control system enables you to tune the drilling process so that you can get the rock drill to perform to perfection. Its intuitive interface is easy to understand so you can get up and running in no time at all. The control system also makes it simple and quick to install new updates in the future. Engine RPM and compressor load are automatically adjusted by the system to ensure that maximum efficiency is achieved throughout the drilling process.



+ Reduced environmental impact

At Epiroc, we believe that an expanding infrastructure doesn't have to damage the environment around us. Our goal is to help your operation be as sustainable as possible. The rig is fitted with a Volvo Penta diesel engine with a smart control system which ensures that fuel is not used unnecessarily. A noise reduction option is also available to ensure that sound pollution is kept to a minimum in sensitive areas.



+ Tough terrain? No problem

The SmartROC T25 R has a low center of gravity to help it stay balanced on rough ground. We've also increased the space between the crawler tracks which helps to improve stability. The boom is also extremely manoeuvrable which makes it a great counter-weight when tramping over uneven ground. A lab-type drill support leg ensures a stable set-up whilst a winch allows you to anchor the machine securely to get up and down steep inclines.



A comprehensive service offering

Even the best equipment needs to be serviced regularly to make sure it sustains peak performance. An Epiroc service solution offers peace of mind, maximizing availability and performance throughout the lifetime of your equipment. We focus on safety, productivity and reliability.

By combining genuine parts and an Epiroc service from our certified technicians, we safeguard your productivity – wherever you are.

Main Components

- Crawler type two speed undercarriage with track oscillation system
- Rubber or steel crawler track options
- Volvo Penta diesel engine
- Atlas Copco screw type compressor
- Versatile folding boom system
- Labb-type drill support leg
- Rockdrill lubrication-oil collection system (ECLR)

- 6 m (45/45°) or 5.7 m (90/90°) of boom reach
- Smart control system with 10" touchscreen
- Hydraulic rock drills COP SC14
- Rod Adding System (RAS)
- High capacity dust collection system, DCT
- 360° feed swing
- Radio Remote Control system with integrated display

Recommended hole range

Feed type	Metric	US	Thread	Rod Adding System (RAS)
				1:1 rods
8 ft feed	Ø 38–64 mm	Ø 1.5"–2.5"	SR32, R32, TC35, T35	3.9 m
10 ft feed				5.1 m
14 ft feed				7.6 m

Engine

Volvo Penta TAD 580 VE turbo-charged diesel engine, Tier 4 Final/Stage V	
Power rating at 1 975 rpm	105 kW/143 hp
Electronic variable engine speed	900–1 975 rpm
Variable fan control	
Green saver – automatic low engine speed	
Volvo Penta TAD 580 VE turbo charged diesel engine, Tier 3	
Power rating at 1 975 rpm	105 kW/143 hp

Dust collector DCT

	Metric	US
Filter area	7 m ²	75 sq.ft
Suction hose diameter	102 mm	4"
Cleaning air pressure, max	7.5 bar	109 psi
Cleaning air consumption at 7 bar	15 l/pulse	0.53 cu.ft/pulse
Filter cleaning while drilling		
7 pcs of filter elements		

Weight

Standard unit excluding all options and drill steel	Metric	US
Provisional max weight - Steel tracks	12 100 kg	26 794 lb
Provisional max weight - Rubber tracks	10 100 kg	21 826 lb

Feed length

8 ft feed (2.4 m)	4 000 mm
10 ft feed (3 m)	4 600 mm
14 ft feed (4.3 m)	5 800 mm

Feed swing

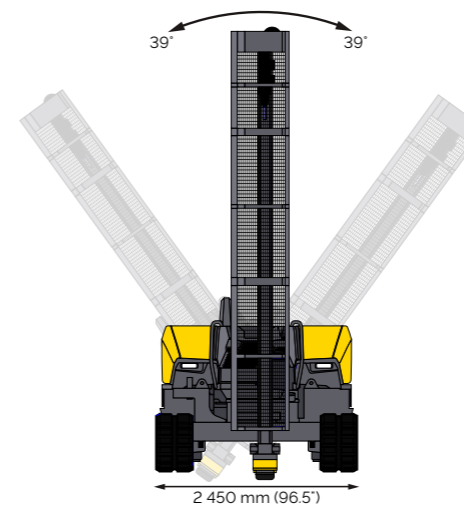

Compressor

Atlas Copco OIS, screw compressor		
Working pressure, max	8.5 bar	123 psi
FAD, at normal working pressure	55 l/sec	14.5 US gal/sec

Feed

Total length	Metric	US
14 ft feed	5 900 mm	232"
10 ft feed	4 700 mm	185"
8 ft feed	4 100 mm	161"
Travel length	Metric	US
14 ft feed	4 242 mm	167"
10 ft feed	3 026 mm	119"
8 ft feed	2 411 mm	95"
Feed extension	Metric	US
10 ft and 8 ft feed	530 mm	21"
14 ft feed	1 000 mm	39"

Hydraulic aluminum cylinder feed with hose guide and single drill steel support with moveable or fixed lower guide/dust hood.

Electrical system

Voltage	24 V
Batteries (AGM)	95 Ah
Alternator	28 V, 130 A
Work lights, front	2 X 35W LED
Work lights, rear	2 X 35W LED
Work lights, feed	2 X 35W LED
Display with diagnostics and settings	

Hydraulic rock drill

Rock drill	Power	Motor
COP SC14	14 kW (18.8 hp)	160 cc 200 cc

Hydraulic system

Anti-jamming		
Rotation Pressure Control feed RPC-F		
Damper Pressure Control - impact DPC-I		
Return and drainage filters F (filtration rate)	10 µm absolute	
Hydraulic oil cooler max ambient temperature	50°C	122°F
(Diesel engine preheater required at -15°C)		

Transport dimensions

Height (H)	2 950 mm (116')
Feed length (L) with 14 ft (4.27 m) feed with feed holder - upper level/STD	6 650 mm (262')
Feed length (L) with 14 ft (4.27 m) feed with feed holder - lower level/rollover	6 000 mm (236')
Feed length (L) with 10 ft (3.04 m) feed	6 350 mm (250')
Feed length (L) with 8 ft (2.44 m) feed	5 750 mm (226')

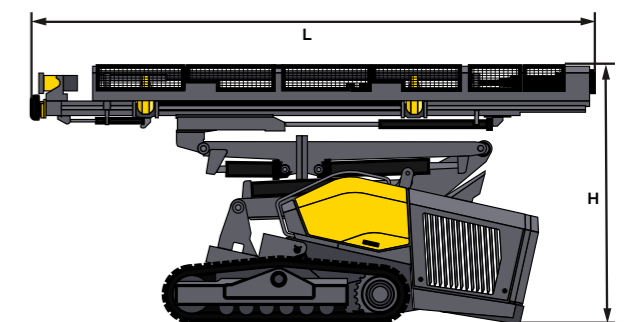

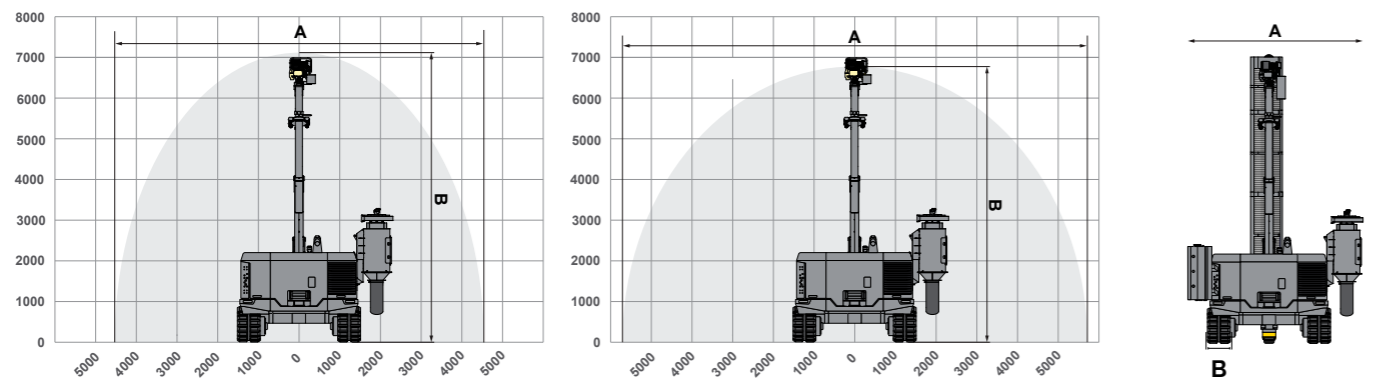
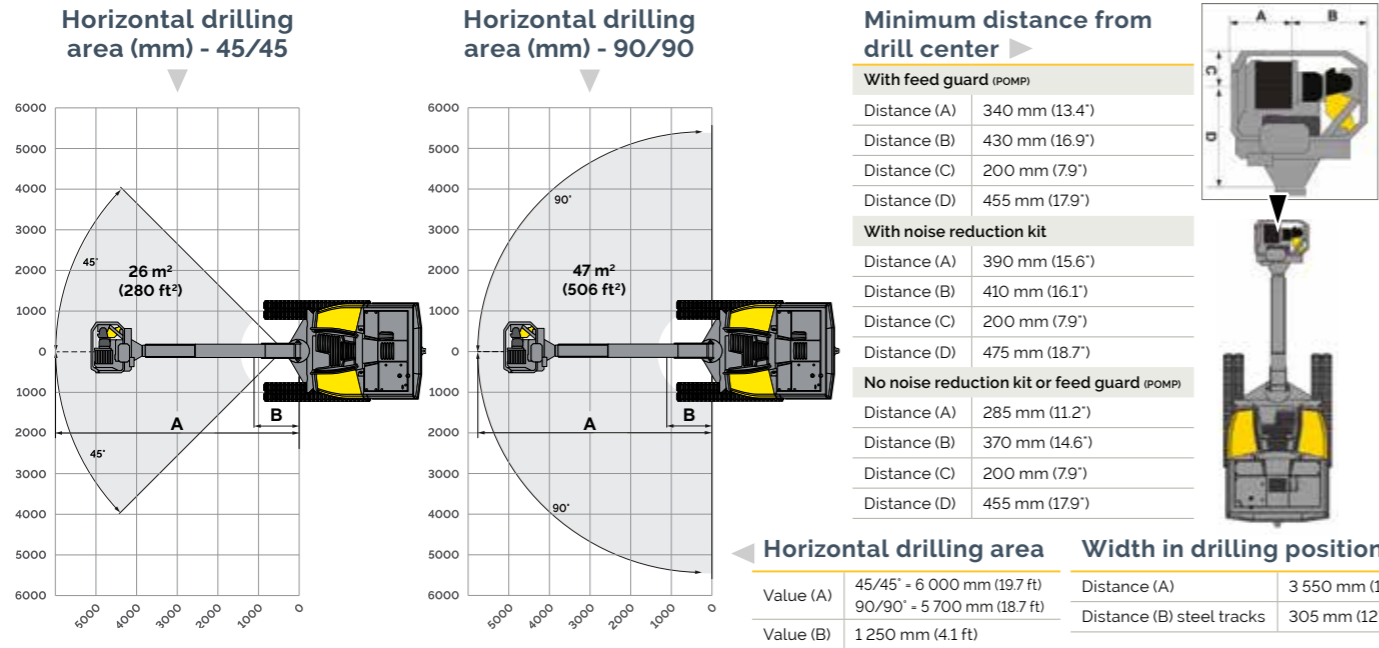

Distance (B)	7 100 mm (23.3 ft)	Distance (B)	6 800 mm (22.3 ft)
Distance (A)	8 950 mm (29.4 ft)	Distance (A)	11 250 mm (37 ft)

Vertical reach

Feed type	Value A	Value B	Value C 90/90	Value C 45/45	Value D
14 ft (4.3 m), feed holder upper level	2 000 mm (6.57 ft)	4 900 mm (16 ft)		6 000 mm (19.7 ft)	1 250 mm (4.1 ft)
14 ft (4.3 m), feed holder lower level	2 750 mm (9.1 ft)	4 150 mm (13.6 ft)		6 000 mm (19.7 ft)	1 250 mm (4.1 ft)
14 ft (4.3 m), roll-over, feed holder lower level	2 750 mm (9.1 ft)	4 150 mm (13.6 ft)	5 700 mm (18.7 ft)		1 250 mm (4.1 ft)
10 ft (3 m) feed	2 350 mm (7.6 ft)	4 150 mm (13.6 ft)		6 000 mm (19.7 ft)	1 250 mm (4.1 ft)
8 ft (2.4 m) feed	2 950 mm (9.6 ft)	3 500 mm (11.5 ft)		6 000 mm (19.7 ft)	1 250 mm (4.1 ft)

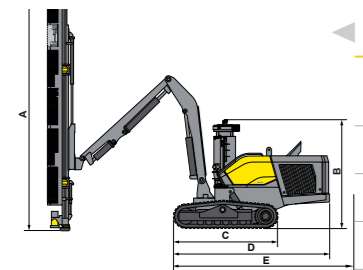

Drilling position dimensions

Height (A) 14 ft feed	5 900 mm (19.4 ft)
Height (A) 10 ft feed	4 700 mm (15.4 ft)
Height (A) 8 ft feed	4 100 mm (13.5 ft)
Height (B) Steel crawler tracks	2 650 mm (8.7 ft)
Height (B) Rubber crawler tracks	2 600 mm (8.55 ft)
Length (C) Steel crawler tracks	2 900 mm (9.5 ft)
Length (C) Rubber crawler tracks	2 700 mm (8.85 ft)
Length (D) Steel crawler tracks	4 250 mm (13.9 ft)
Length (D) Rubber crawler tracks	4 050 mm (13.3 ft)
Length (E) Steel crawler tracks	4 600 mm (15.1 ft)
Length (E) Rubber crawler tracks	4 450 mm (14.6 ft)

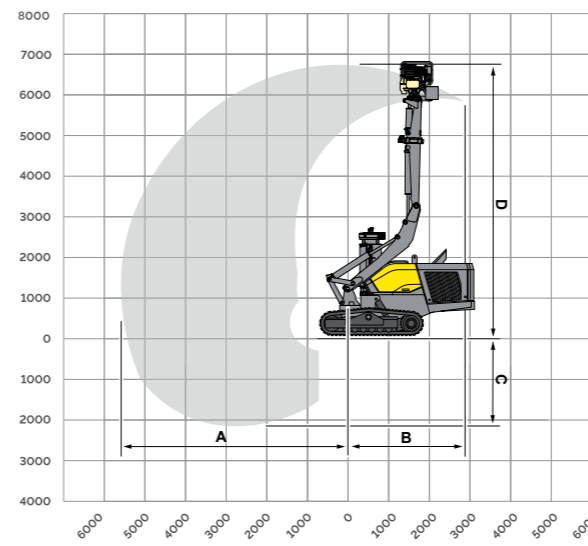
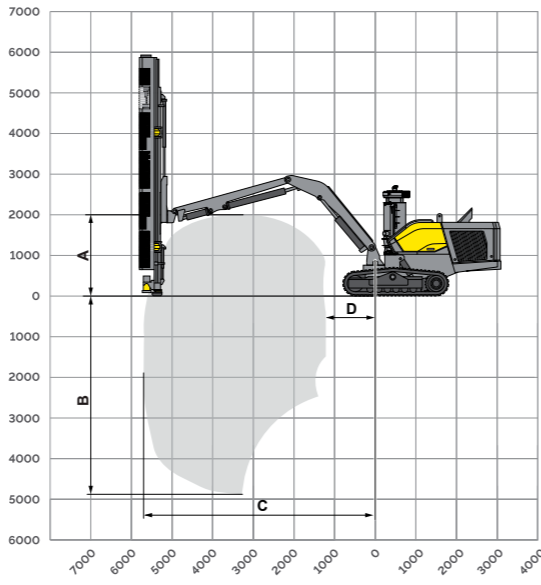

Vertical upwards drilling

Feed type	Minimum Height	Maximum Height
14 ft	6 150 mm (20.2 ft)	9 550 mm (31.3 ft)
10 ft	4 900 mm (16 ft)	8 850 mm (29 ft)
8 ft	4 300 mm (14.1 ft)	8 200 mm (26.9 ft)

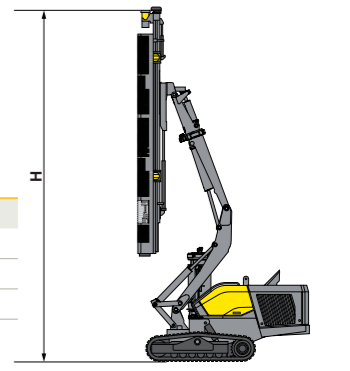

Horizontal side drilling area with roll-over

	Hydraulic roll-over 90/90	Hydraulic roll-over 45/45
Distance (A)	5 600 mm (18.4 ft)	5 900 mm (19.3 ft)
Distance (B)	3 000 mm (9.8 ft)	3 950 mm (12.9 ft)
Distance (C)	2 150 mm (7 ft)	2 150 mm (7 ft)
Distance (D)	6 750 mm (22.1 ft)	7 050 mm (23.1 ft)

Minimum distance from drill center

Distance (A) - feed in vertical position	200 mm
Distance (C) - feed inclination 5° (B)	130 mm

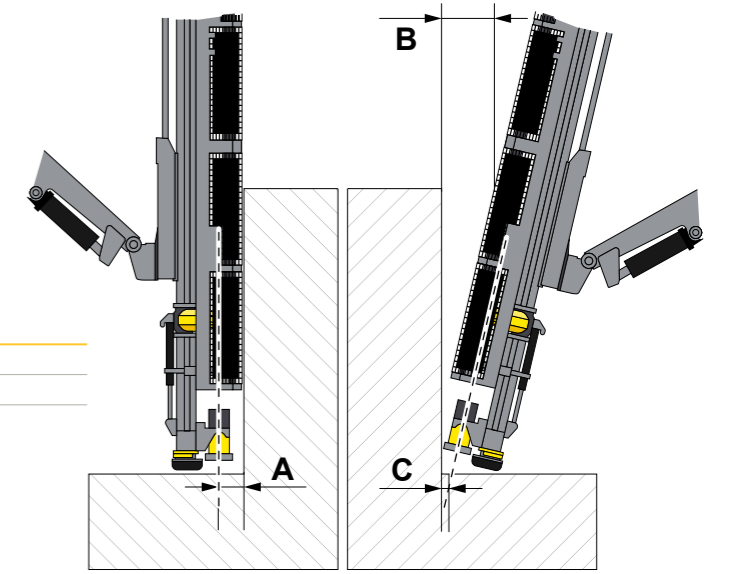

Options list

Feed and boom

- Movable suction hood/drill-steel support
- 90 + 90° boom swing device
- Hydraulic roll-over
- Protection of Moving Parts (PoMP)
- Rubber disc for DCT
- Rubber hood for DCT
- Noise reduction kit
- Thread lubrication system - ECG

Carrier

- Grind Matic RH4 — bit grinder
- Programmable blast horn
- Central Lubrication System (CLS)
- Diesel-driven engine heater
- Electric fuel-filling system
- Hydraulic winch
- Steel crawler tracks
- Rubber crawler tracks

Hole and inclination systems

- GPS compass aiming unit
- GNSS compasses for aiming, height control and hole logging
- Hole navigation system with remote display

Additional options

- Spare radio transmitter (radio remote control)
- Hydraulic waterpump for waterflushing
- Water mist system with 150 L tank and hydraulic pump
- Water mist system with 50 L tank and hydraulic pump
- Extra lights
- Hydraulic AUX outlet
- Bag handling system for DCT

Additional options - not mounted

- Basic toolkit
- Conversion kit R32 (rigs with steel crawlers)
- Conversion kit SR32 (rigs with steel crawlers)
- First 50 hrs service kit for compressor
- Gas charging equipment for rock drill
- Lubrication kit
- Belt for radio remote control (RRC)/OU
- Parts book – hard copy

United in performance. Inspired by innovation.

Performance unites us, innovation inspires us, and commitment drives us to keep moving forward. Count on Epiroc to deliver the solutions you need to succeed today and the technology to lead tomorrow.
[epiroc.com](https://www.epiroc.com)

