

# Christensen CT20

Surface core drilling rig for deep hole exploration drilling

Hole size: B, N, H and P





# Modern deep hole drilling

Christensen CT20 has a drilling depth capacity of 2 450 meters. The rig comes truck-mounted or crawler-mounted, which means it can be easily transported.

Despite its power, the Christensen CT20 is easy to run thanks to an intuitive control panel which makes it easy to operate the numerous functions. The work environment around the Christensen CT20 has also

been a focus throughout the development process. For example, the Tier 4 version of this rig is equipped with a sound reducing engine canopy.



## ⊕ Main benefits

**Safety is ensured** thanks to safety guards around hot or moving parts

**Powerful drilling** thanks to a large drilling depth capacity and feed system

**High efficiency** thanks to a sturdy mast capable of handling six meter core barrels



# High productivity at great depths

The Christensen CT20 is safe, ergonomic and environmentally friendly. The rig is a perfect choice for surface core drilling anywhere in the world. Available with truck or crawler mounted versions, the Christensen CT20 can easily be transported and manoeuvred.



## + Safe and compliant

Concern for safety, ergonomics and the environment is more than a competitive advantage – it is a requirement in most markets. Our Christensen CT20 is equipped with the required safety guards around hot or moving parts. It's also available with Tier 3 and Tier 4 Final engine options.



## + Productive and powerful

Christensen CT20 is powerful and easy to operate thanks to a user-friendly control panel with several automated features. A newly designed feed system and a drilling depth capacity of 2 450 meters further enhances productivity. Christensen CT20 is capable of carrying the full weight of the drill string and 6 meter core barrels allowing for more core in the box.



## + Premium parts and professional service

Rely on Epiroc to provide you with expert machinery as well as all the additional parts and services you may require to get the most out of your investment. We offer a full range of premium drill rods, core barrels, core drill bits and casings. No matter where you work in the world, Epiroc is at your service with dependable parts and professionals.

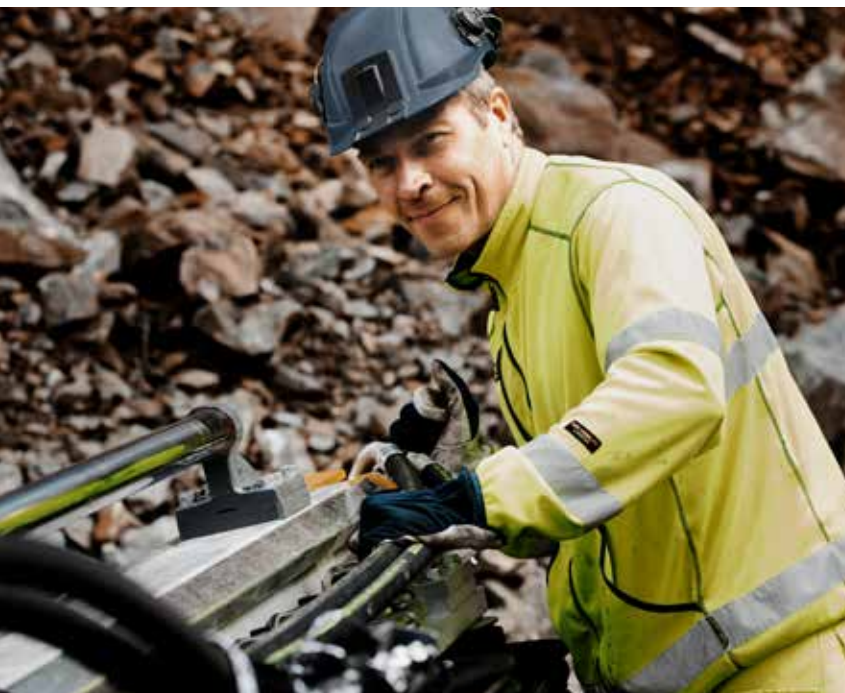

## A comprehensive service offering

Even the best equipment needs to be serviced regularly to make sure it sustains peak performance. An Epiroc service solution offers peace of mind, maximizing availability and performance throughout the lifetime of your equipment. We focus on safety, productivity and reliability.

By combining genuine parts and an Epiroc service from our certified technicians, we safeguard your productivity – wherever you are.

## Technical specifications



Discover more about the Christensen CT20.

**Main hoist** - Dimensioned to handle the total rod weight at the maximum drilling capacity.

**Rotation unit** - Consists of a hydraulic motor, sealed gearbox, hollow spindle and hydraulic chuck. The rotation speed is adjustable from the control panel.

**Mast dump** - Ensures hole straightness by stabilizing the mast when it is raised.



### Depth capacity

Hole size	Standard drill rods		Thin wall drill rods	
	Metric	US	Metric	US
B wireline	3 417 m	11 211 ft	4 059 m	13 317 ft
N wireline	2 694 m	8 839 ft	3 073 m	10 082 ft
H wireline	1 788 m	5 866 ft	2 446 m	8 025 ft
P wireline	1 092 m	3 583 ft	1 713 m	5 620 ft

These figures serve as guidelines only. They are calculated with available pull force from main winch, weight of drill string in water filled hole and average WOB. Epiroc cannot guarantee these capacities will be reached in all working conditions due to varying factors such as ITH used, conditions of the ground and differences in operation.

### Main winch

	Metric	US
Single line capacity, automatic speed adjustment depending on the load	178 kN	40 000 lb
Line speed @ max displacement	34 m/min	17 ft/min
Line speed @ min displacement	72 m/sec	232 ft/min
Cable dimensions telescopic	33 m x 24 mm	108 ft x 1"
Cable dimensions standard	29.5 m x 24 mm	97 ft x 1"

### Wireline winch with level wind

	Metric	US
Capacity	3 600 m of 4.76 mm 2 500 m of 6.35 mm recommended	12 130 ft of -3/16" 8 202 ft of 1/4" recommended
Line pull, bare drum	18.6 kN	4 181 lb
Line pull, full drum	4.2 kN	944 lb
Cable size, bare drum	76 m/min	249 ft/min
Cable size, bare drum	337 m/min	1 106 ft/min

### Mast and feed system

	Metric	US
Feed stroke	3.5 m	11.5 ft
Mast dump	2 m	6.56 ft
Thrust	100 kN	22 480 lb
Pull	200 kN	45 000 lb
Rod pull length	6.09 m or 9.14 m on telescopic mast	20 ft or 30 ft on telescopic mast

### Power unit

Cummins QSL 9, Diesel turbo-charged and Charged Air Cooled	Metric	US
Volume	8.9 liter	2.3 gallons
Power	Tier 3: 224 kW Tier 4F: 231 kW	Tier 3: 300 bhp Tier 4F: 310 bhp
RPM	2 100	2 100
Electrical system	24 V	24 V
Sound level	Tier 3: 113 dB / Tier 4: 116 dB	Tier 3: 113 dB / Tier 4: 116 dB
Cooling	Water	

### Rod holder

	Metric	US
Maximum clamping diameter, PW Casing	139.7 mm	5.50 in
Clamping force	200 kN	45 000 lb

### Hydraulic system

	Metric	US
Primary pump	310 bar - 295 L/min	4 500 psi - 78 gal/min
Secondary pump	200 bar - 170 L/min	2 900 psi - 45 gal/min
Auxiliary pump	215 bar - 55 L/min	3 118 psi - 14.5 gal/min
Hydraulic oil cooling	Air	

# Technical specifications

## Rotation head and spindle speeds

	Metric	US
Spindle opening and pass capacity	124 mm	4.88 in
Max Torque	8 150 Nm	6 011 ft lb
Power	Hydraulic motor – variable speed/reversible	
2-speed gear box	Hydraulic slidable rotation unit	

## Spindle speed

Ratio	Speeds, rpm	Torque, Nm	Torque, ft lb
1st 17.55:1	50 – 200	8 175 – 3 775 Nm	6 030 – 2 784
2nd 2.70:1	350 – 1 300	1 860 – 860 Nm	1 372 – 634

## Chuck assembly

Hydraulic open, spring closed	Metric	US
Maximum clamping diameter	124 mm	4.88"
Holding capacity	223 kN	50 132 lbs

## Mud pump

TRIDO 140H	Metric	US
Flow	140 l/min	37 gal/min
Pressure	68.95 bar	1 000 psi

## Ground pressure

Rig model	Metric	US
CT20 Crawler	0.80 daN/cm <sup>2</sup>	11.52 psi

## Options

Radio-controlled crawler

## Pilot-controlled control panel

The user-friendly and ergonomic control offers the following features:

Joystick for making & breaking
Auto thread compensation
Thread compensator to prevent damage on threads when making/breaking the joints
Engine RPM
Feed force and hold back in kN
LED screen lighting
Rotation working hours
Make up torque limitation
Constant penetration rate
Hold back force and adjustment valve offering accurate and easy setting on weight on bit (WOB) to improve penetration rate and bit life.
Water flow and pressure
Function lever
Rotation unit RPM

## Sound\*

	Tier 3	Tier 4 Final
A-weighted Sound Power Level, LWA	113 dB	115 dB
	Tier 3	Tier 4 Final
A-weighted sound pressure level, LpA, calculated (4 m distance from rig)	93 m	95 dB

\*The declared noise emission values should be combined with a measurement uncertainty of KpA-3 dB. The sum of declared measured value and the uncertainty value represent an upper limit of the range, in which measured values are likely to be included. The values were determined in accordance with the standards ISO 3744:2010 (for sound power level estimation) and ISO 11203:1995 (for sound pressure calculation at different distances from the rig).

## Main components

Hydraulic mast dump
Safety guards (with inter-lock)
User-friendly control panel
Hydraulic oil reservoir fill pump & filtration
Make and brake with joy-stick
Ladder kit with safety system
WL winch with Level-wind and Parking Brake
Hydraulic jacks (spreadable)
Hydraulic rod holder (PW)
Fuel tank 950 l (251 gal)
High Altitude capacity
Hydraulic Mud Mixer
Walk ways
Hydraulic pressure filters
Maintenance platform
9 m (30 ft) telescopic mast

## Working dimensions

Dimension	Christensen CT20		Christensen CT20C	
	Metric	US	Metric	US
A	8 585 mm	338"	8 560 mm	337"
B	11 570 mm	456"	11 570 mm	456"
C	650 mm	26"	122 mm	5"
D	1 320 mm	52"	1 043 mm	41"
E	3 710 mm	146"	3 470 mm	137"
F	7 630 mm	300"	7 630 mm	300"
G	10 940 mm	431"	10 940 mm	431"
H	14 420 mm	568"	14 420 mm	568"

## Transport dimensions with mast in transport mode

Dimension	Christensen CT20		Christensen CT20C	
	Metric	US	Metric	US
I	2 500 mm	98"	500 mm	20"
J	3 200 mm	126"	2 430 mm	96"
K	11 920 mm	470"	11 920 mm	469"
L	3 670 mm	145"	3 780 mm	149"
M	2 690 mm	106"	2 860 mm	113"
N	2 430 mm	96"	2 570 mm	101"
O	3 720 mm	147"	3 720 mm	146"
P	5 500 mm	217"	5 540 mm	218"
Q	2 560 mm	101"	2 660 mm	105"

## Weight

Dimension	Metric	Imperial
CT20 complete rig, including all fluids	18 000 kg	40 000 lb
CT20C complete rig, including all fluids	24 000 kg	52 911 lb

# Technical specifications

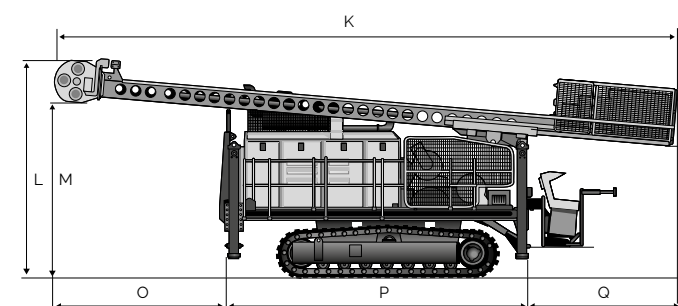
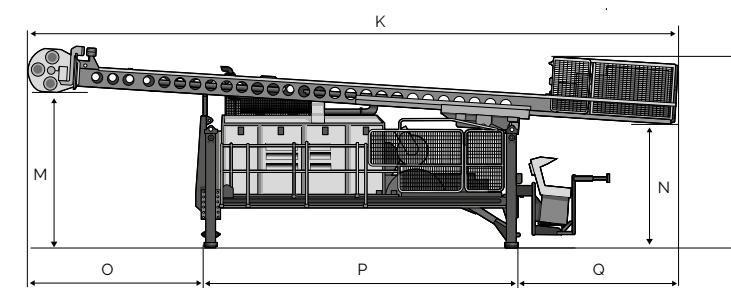
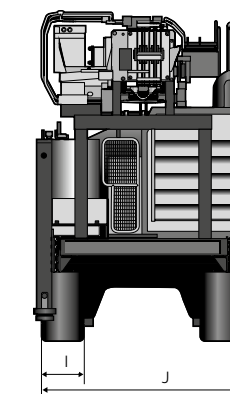
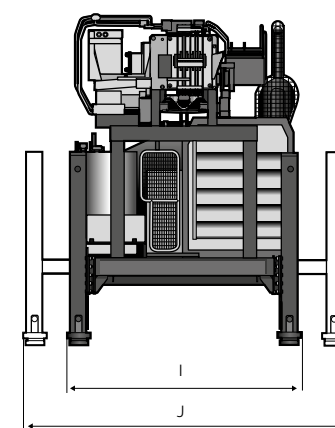
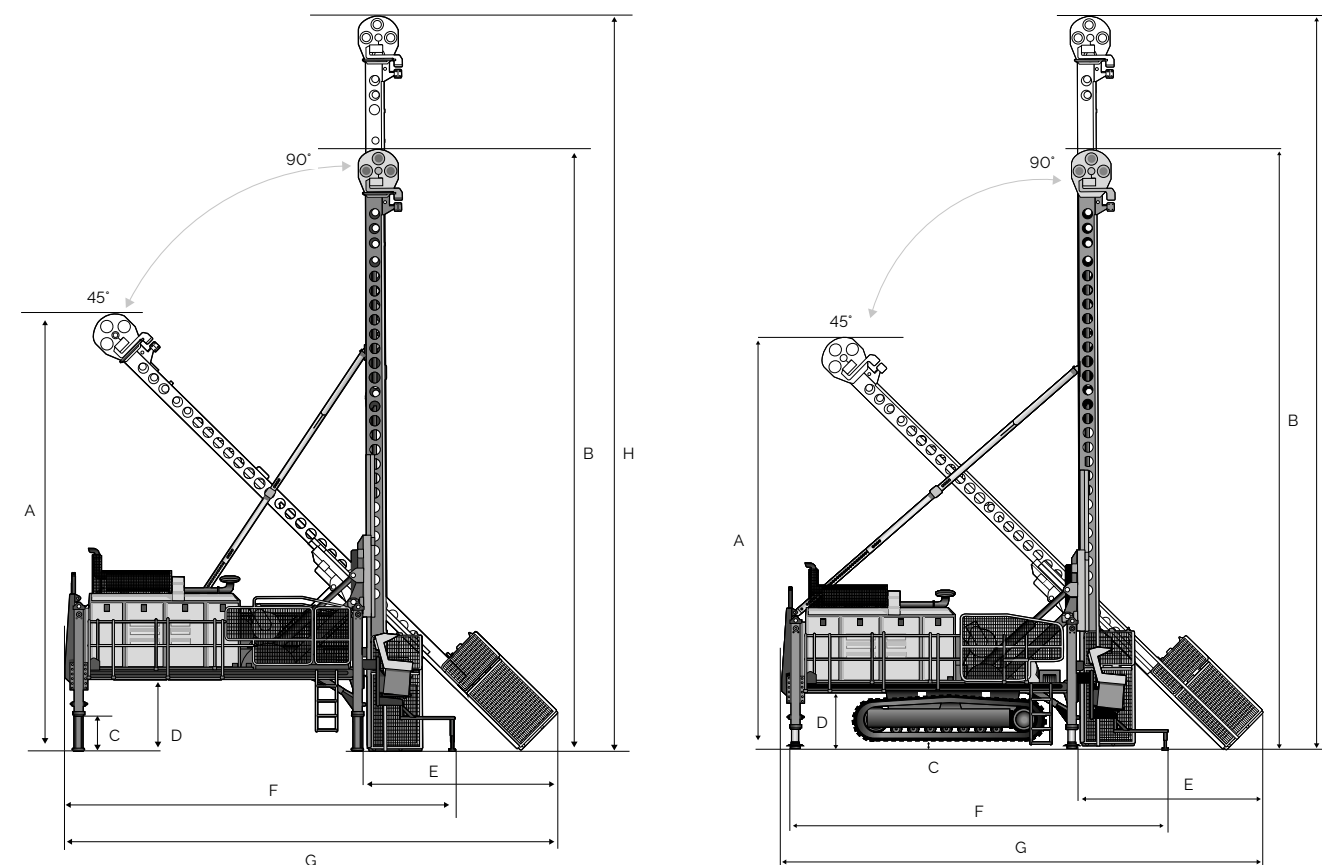



# Minimise on-site danger

The Christensen Rod Handler System (RHS) is available as an option for both the Christensen 140 and Christensen CT20 surface core drilling rigs.

Safety is always a top concern and sometimes surface core drilling can be challenging in terms of operator safety. This is why we developed the Rod Handling System. The Christensen RHS enables hands-free rod tripping throughout the drilling cycle, which means there is no need to manually add or remove rods by hand. Secondly, thanks to hands-free rod tripping

the operator assistant is able to handle the assistant control panel instead of manually adding the rods. This means less fatigue for the operator assistant. Lastly, safety is further improved by reducing the amount of injuries during the rod loading process. This is achieved thanks to not having to manually add rods when threading.



## ⊕ Main benefits

**Hands-free rod tripping** throughout the drilling cycle

**Less fatigue** for the operator assistant

**Minimise injuries** during the rod-loading process



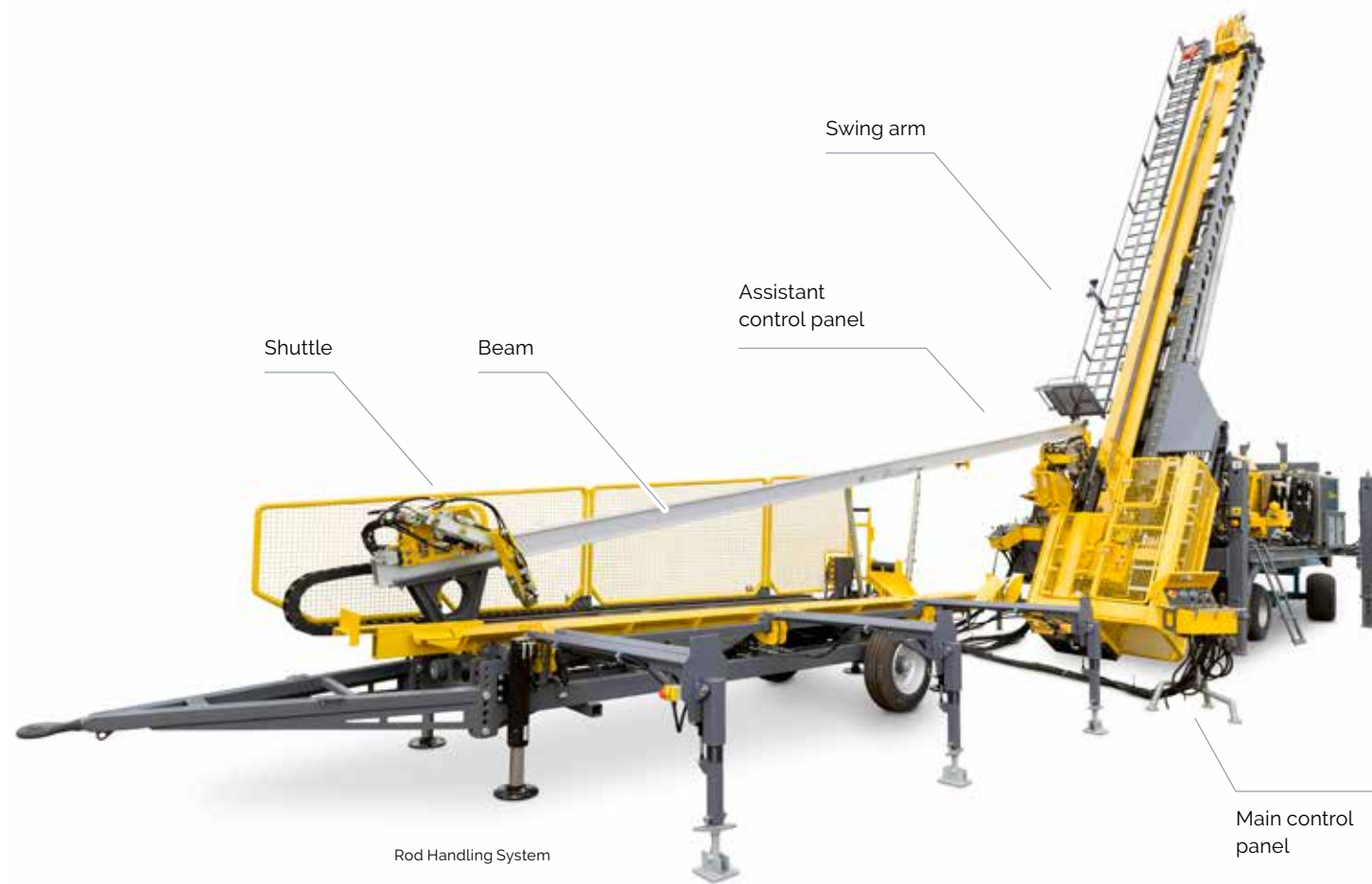

**Technical data**

Main application area	Core drilling
Drilling method	Wireline drilling
Rod rack capacity	B - 25 rods, N - 20 rods, H - 15 rods, P - 11 rods
Powered by	Rig auxiliary hydraulic
Transport dimensions	8 250 x 1 700 x 2 150 mm
Weight	2 500 kg

**Working dimensions**

Dimension	Metric	US
A	4 698 mm	185'
B - P1	5 124 mm	202'
C - P1	10 617 mm	418'
D - P1	16 207 mm	638'
E	2 923 mm	115'
F - P2	5 493 mm	216'
G - P2	11 278 mm	444'
H - P2	16 867 mm	664'

**Technical data**

Handles 3 meter and 6 meter drill rod
Rod size - B, N, H and P
Can handle WL casings
Handles the complete core barrel as well as inner tube
Drilling angles from 45° to 90°
CE certified (EN 16228)

**Transport dimensions**

Dimension	Metric	US
Length	8 250 mm	325'
Width	2 150 mm	85'
Height	1 700 mm	67'

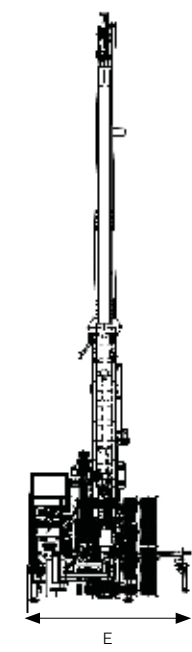
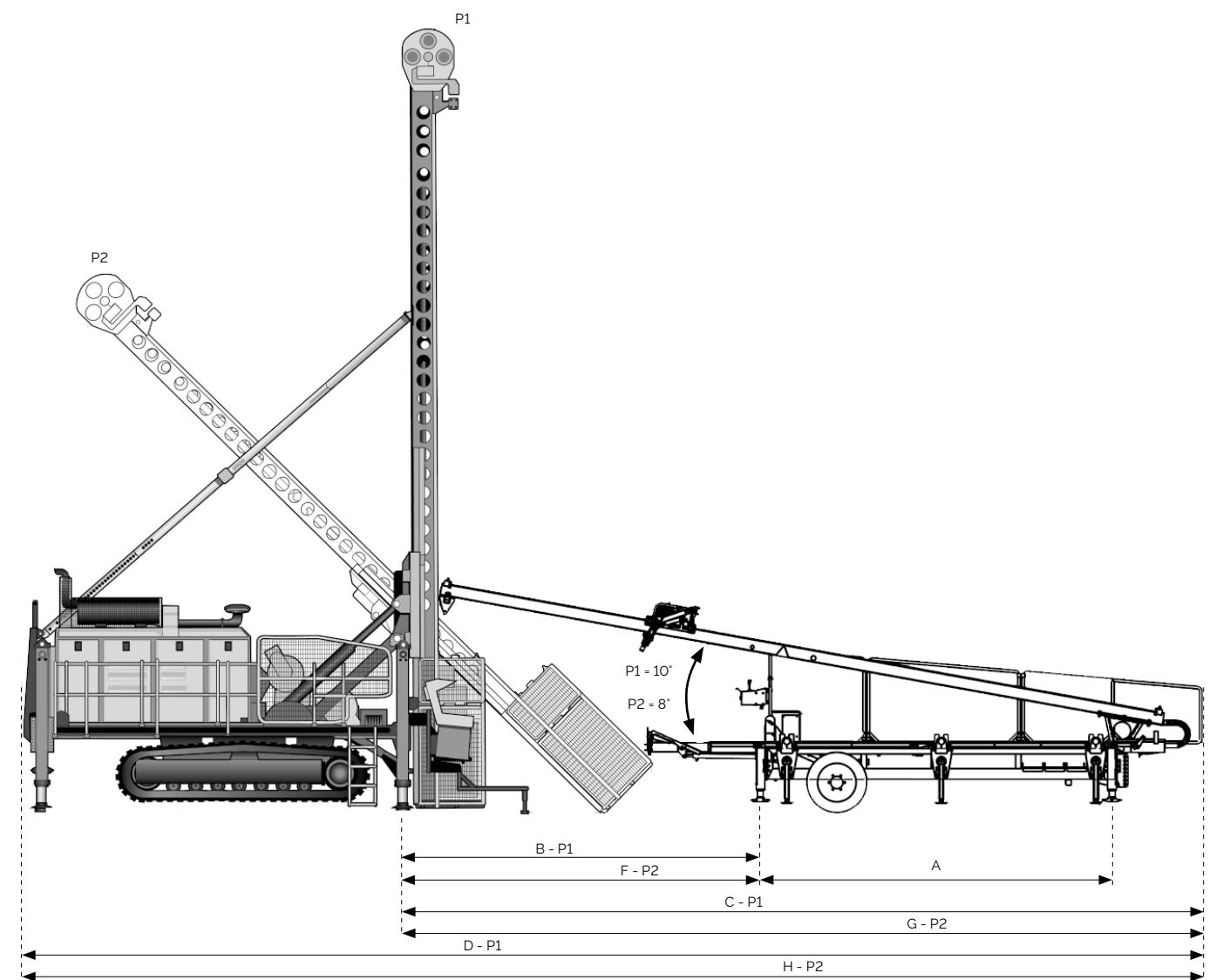

# United in performance. Inspired by innovation.

Performance unites us, innovation inspires us, and commitment drives us to keep moving forward. Count on Epiroc to deliver the solutions you need to succeed today and the technology to lead tomorrow.  
**[epiroc.com](https://www.epiroc.com)**

