

Terrah TS100 SC

Underground rock scaler for small to medium-sized tunnels



Safe and productive rock scaling

Terrah TS100 SC is a reliable rock scaler developed for demanding underground operations in small to medium-sized tunnels. Operator safety is prioritized throughout the entire operation, featuring robust protection against falling objects, excellent visibility and easy maneuverability. The strong telescopic boom and hydraulic hammers maximize your productivity, through precise rock scaling and reach of more than 6.5 meters in a single setup.

Enclosed, air-conditioned, ISO FOPS and ROPS-approved operator cabin with low noise levels, placed far from the operation

Terrah electronic controller offers efficient machine control and data logging from the multi-functional display

Spacious cabin with a swingable seat for improved operator ergonomics and visibility

+ Main benefits

Operator safety – the enclosed ROPS and FOPS-approved cabin is placed at the carrier's rear, keeping the operator under supported ground and providing excellent visibility of the scaling operation. Equipped with protective grids on the boom and windows, and integrated dust suppression system for additional safety.

Heavy-duty design – engineered for demanding scaling conditions with reliable and well proven components, a strong boom fitted with large wear plates, a protected boom extension cylinder, and dozer blade to improve road access.

Productivity – minimal time spent between different faces thanks to the compact design and great maneuverability. From a single setup, the telescopic boom reaches an impressive height and provides precise control for accessing a large area.

Built to deliver. Designed to adapt.

The Terrah Series of utility vehicles are designed to maximize modularity, productivity and safety in small to medium-sized underground mining and civil construction tunnels. Built on a legacy of reliable, durable products now enhanced with Epiroc technology, the Terrah Series supports customers throughout their operations.

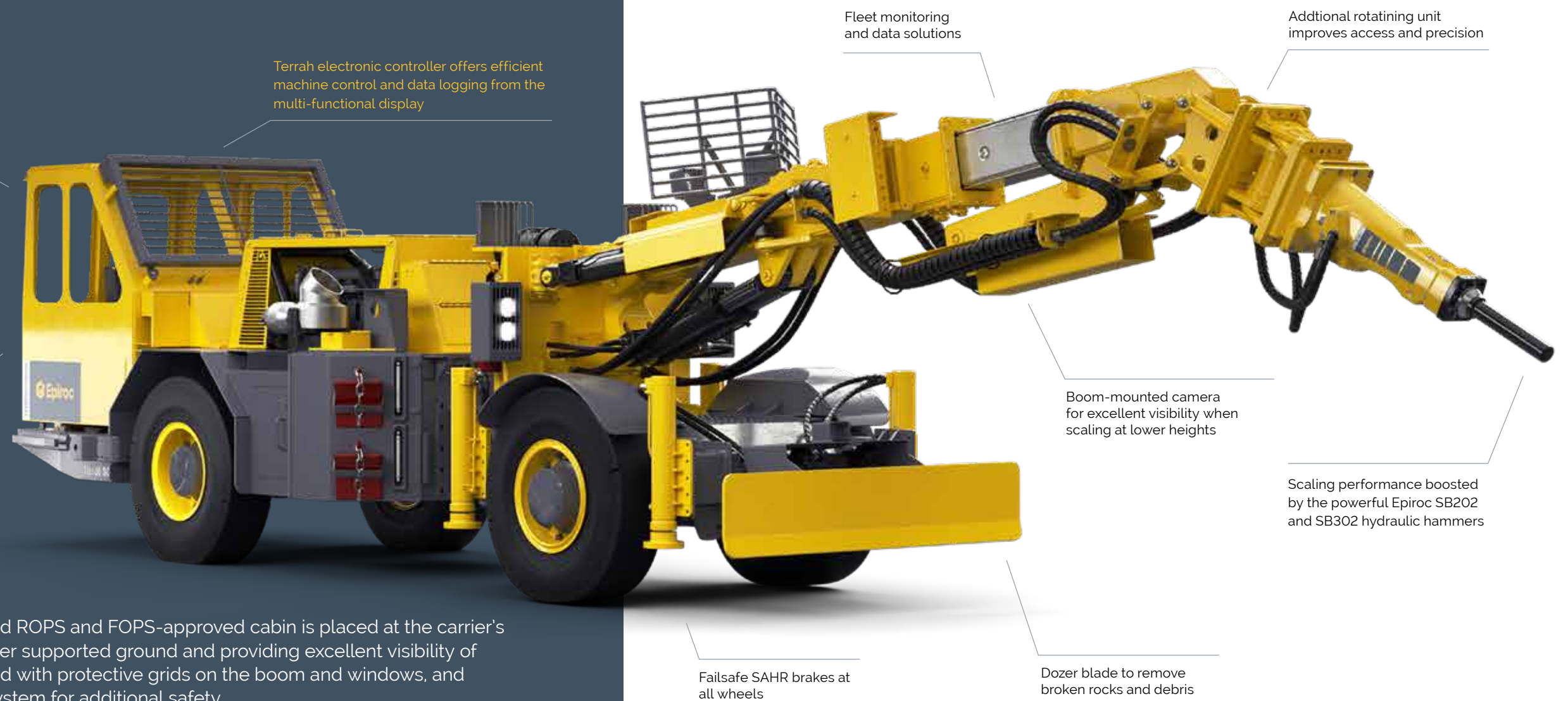

Fleet monitoring and data solutions

Additional rotating unit improves access and precision

Boom-mounted camera for excellent visibility when scaling at lower heights

Scaling performance boosted by the powerful Epiroc SB202 and SB302 hydraulic hammers

Failsafe SAHR brakes at all wheels

Dozer blade to remove broken rocks and debris



Engine

	Standard	Alternative
Brand/model	Deutz TCD914 L6 Tier III	Deutz BF6L914 Tier II
Power at sea level	129.2 kW @ 2300 rpm	104 kW @ 2300 rpm
Cooling	Air	Air
Engine control	Deutz EMRII	Deutz EMRII

Fuel

Fuel tank capacity	140 liter
--------------------	-----------

Exhaust system

Catalytic exhaust gas purifier	●
Fume diluter	●
Diesel Particulate Filter (DPF)	○

Transmission

Brand/model	Dana
Dana/20000 series power shift transmission	●

Axles

Brand/model	Dana/113
Differential: front open	●
Differential: front, no-spin	○
Differential: rear open	●

Brakes

Wetted fully enclosed immersed brake disks	●
Spring Applied Hydraulic Released (SAHR) fail safe brakes - park/emergency	●
Manually activated park/emergency brake valve	●
Foot pedal activated hydraulic service brake	●

Specifications

Capacities	
Maximum hammer height	6 700 mm
Maximum coverage area	50 m ²
Weight*	
Weight, empty	14 050 kg
Axle load, front	7 365 kg
Axle load, rear	6 685 kg

*Weights are approximate and given with filled fluids and standard configured vehicle

Tires

Tire size front and rear	1200 x 20
Air filled tires	●
Polyurethane foam filled tires	○

Performance

Maximum speed on level ground	
Gear 1	5 km/h
Gear 2	11 km/h
Gear 3	27 km/h

Electrical system

System voltage	24V
Alternator	80 Amps
Battery	2 x 110 Ah
Lockable double pole battery isolator switch	●
Engine starter isolation switch	○
Electric starter	●
Key switched ignition	●
Inlet plug for jump start	○
4 x front headlight LED	●
2 x rear drive lights LED	●
Directionally controlled drive lights	●
Amber rotating light	●
Reverse warning light and alarm	●
Brake lights	●
Orange turning direction indicator lights	●
Red and green marker lights	○

Control system

Terrah electronic controller	●
Robust water-resistant digital display	●
On-screen push button interface	●
Power Distribution Modules (PDM)	●
Electronic pressure sensors	●
Speedometer	●
Overspeed control	●
Decline speed control	●
Delayed engine shutdown	○
Inclinometer	●
Block out 3rd	○
Door Open Brake Applied (DOBA)	●
Neutral gear brake (NBA)	●
CAS interface	○
Seat belt switch interlock	○
Joystick boom control	●

Digital products

Fleet monitoring with Fleet+ on My Epiroc	●
Machine and fleet data via APIs	●

Hydraulic system

Gear pumps: brakes and steering	●
Auxiliary hydraulic power take-off (PTO): Gear pump	●
System pressure up to 280 Bar	●
11 µm return line filter	●

Safety system

3 x emergency stop buttons	●
2 x 9 kg handheld fire extinguishers	●
ANSUL manual dry fire suppression system	○
ANSUL FIRECHECK automatic dry fire suppression system	○

Main system

Steel fabrication construction	●
Bolt-on operating cabin	●
Front axle oscillation of 5° both sides	●
Integral hydraulic and fuel tanks	●
Centre articulated steering	●
Two double acting hydraulic steering cylinders (pull/push)	●
Steering lock bar	●
3-point of contact for boarding/exit	●
Front towing attachment with towing pin	●
Telescopic boom	●
Height adjustable pusher blade	●
Quick attachment bracket	●
Hammer movement with rotary actuator	●
Central automatic lubrication system	●
Central manual lubrication system	○
Wiggins fast fuel and oil filling system	○
Wiggins central service points	○
2 x stop blocks (wheel chocks)	●

Operator's compartment

FOPS- and ROPS certified	●
Single operator location for driving and scaling	●
Windows, front window washers and wipers	●
Temperature and fan speed adjustable air conditioner	●
Canopy (no windows or air conditioner)	○
Steel grid protection over windows	●
Steering wheel	●
Suspension and height adjustable, swingable, operator's seat	●
Canvas seat covers	○
Operator seat fitted with 2-point seat belt	●
External camera with a monitor, split screen	●

Hammer

Epiroc SB202	●
Epiroc SB302	○

Technical documentation

Instruction manual, one hardcopy	●
Spare parts manual, one hardcopy	●
PDF manuals on USB flash drive, two per machine	●

Painting and marking

Standard painting and taping	●
------------------------------	---

Technical specifications

Measurements

The dimensional drawings are shown in millimeters, and based on the standard vehicle configuration.

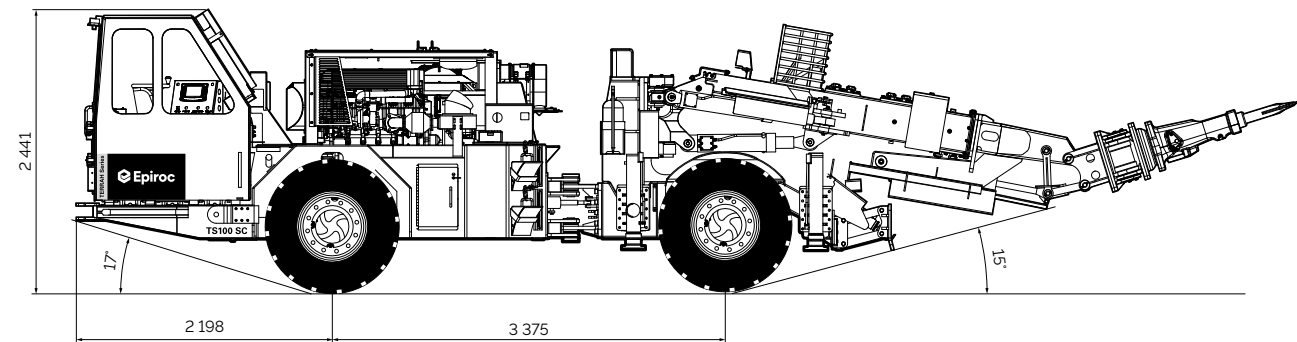

Left side view of Terrah TS100 SC

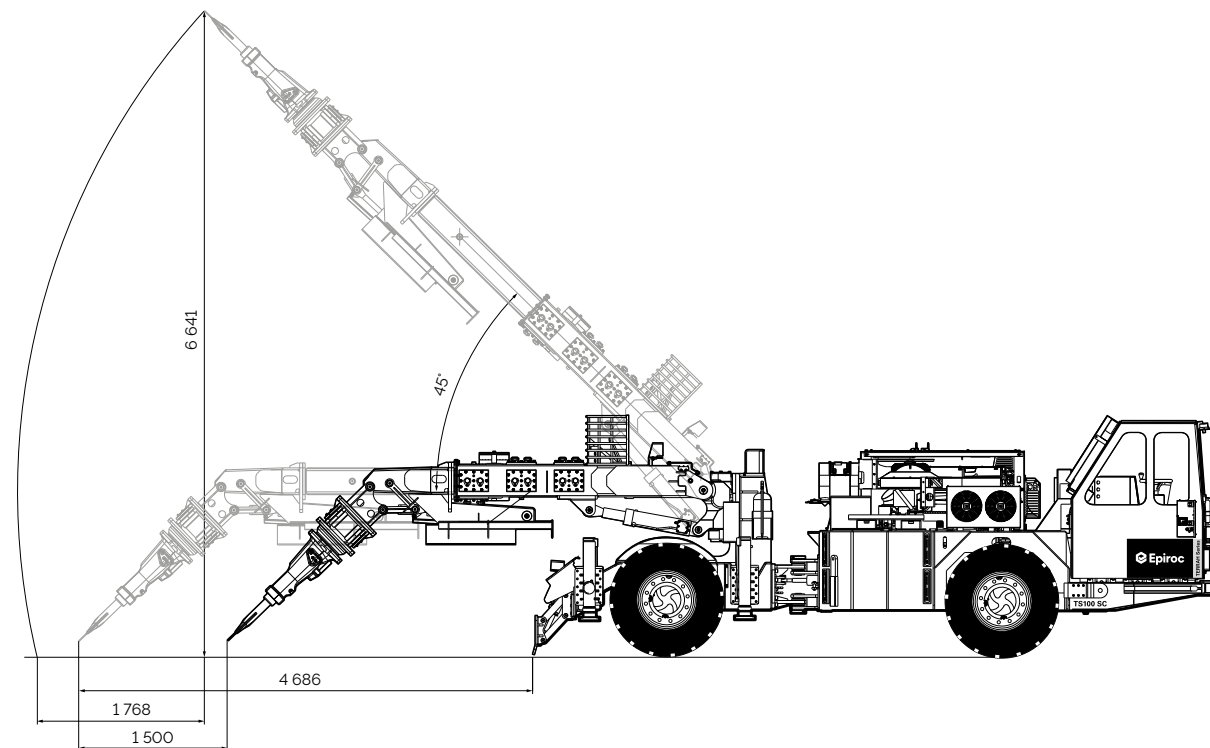

Right side view of Terrah TS100 SC

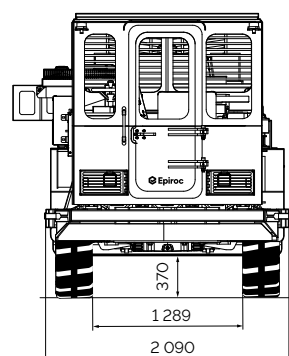

Front view of Terrah TS100 SC

Technical specifications

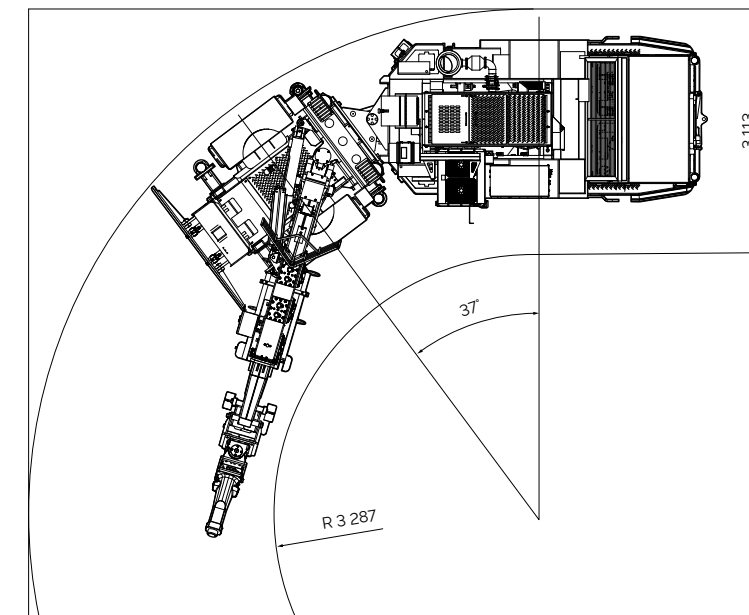

Turning radius of Terrah TS100 SC

A comprehensive service offering

Even the best equipment needs to be serviced regularly to make sure it sustains peak performance. An Epiroc service solution offers peace of mind, maximizing availability and performance throughout the lifetime of your equipment. We focus on safety, productivity and reliability.

By combining genuine parts and an Epiroc service from our certified technicians, we safeguard your productivity - wherever you are.



United in performance. Inspired by innovation.

Performance unites us, innovation inspires us, and commitment drives us to keep moving forward. Count on Epiroc to deliver the solutions you need to succeed today and the technology to lead tomorrow.
[epiroc.com](https://www.epiroc.com)

